

HANGAR

OUTDOOR

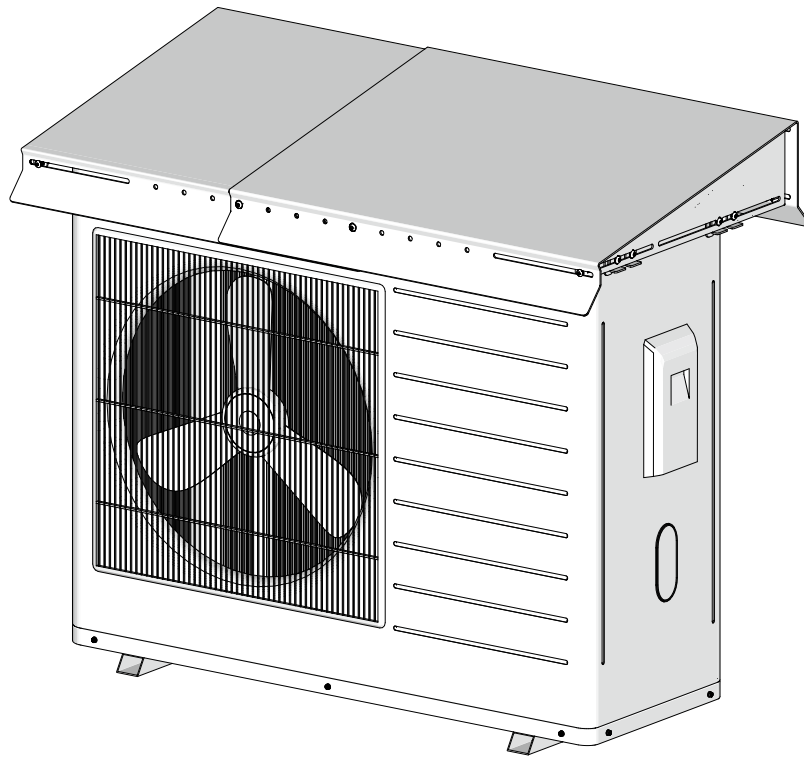

SNOW CAP

ASSEMBLY INSTRUCTIONS

INSTRUCTIONS:

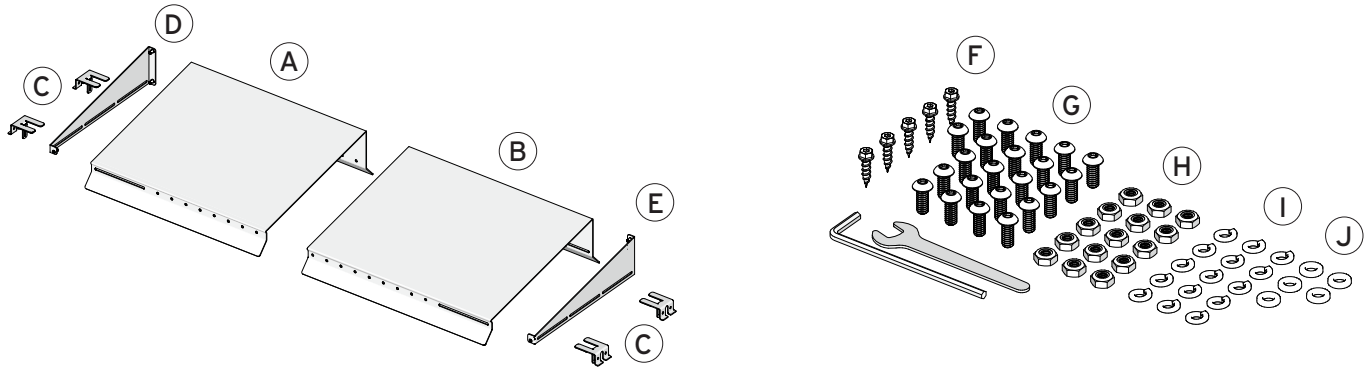

STEP 01:

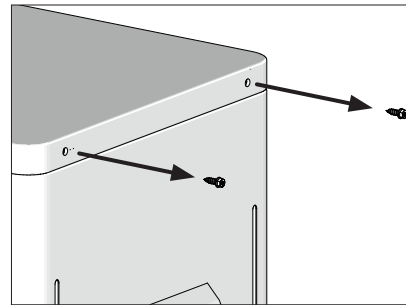
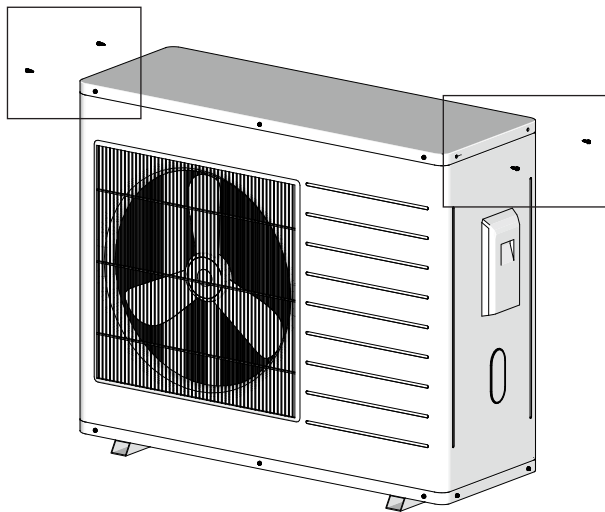

REMOVE EXISTING
HARDWARE FROM LID
OF MINI SPLIT SIDES

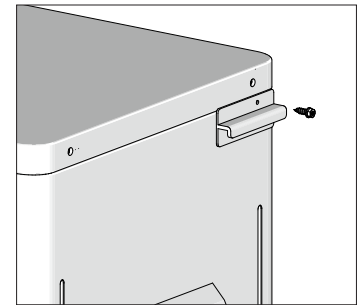

****IF PRESENT****
REMOVE HANDLE

STEP 02:

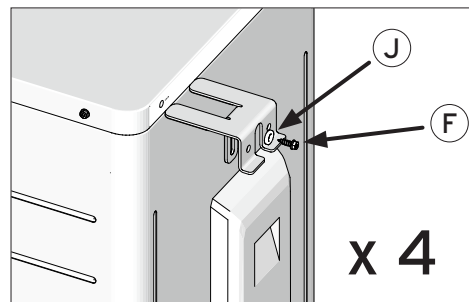
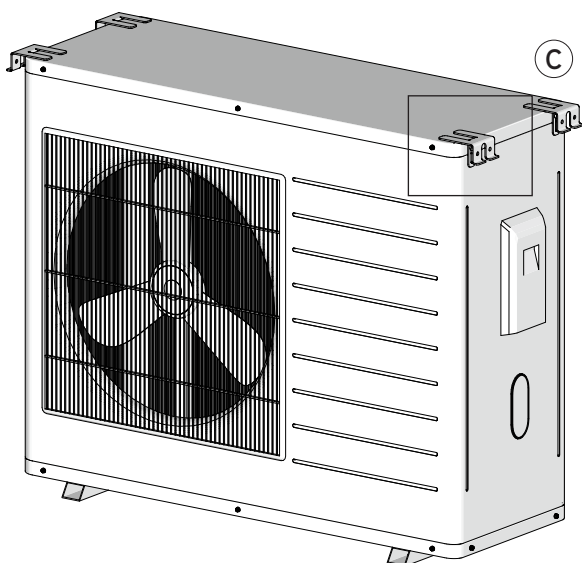

ATTACH 4X BRACKETS (C) WITH THE
HARDWARE YOU JUST REMOVED.

IF EXISTING HARDWARE IS TOO SHORT,
USE LONGER SCREWS (F), PROVIDED.

PLACE WASHER (J) BETWEEN
BRACKET AND SCREW.

STEP 03:

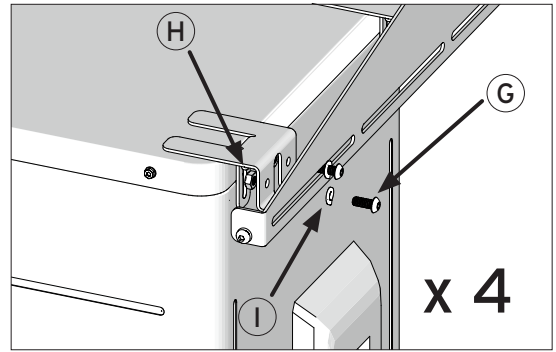
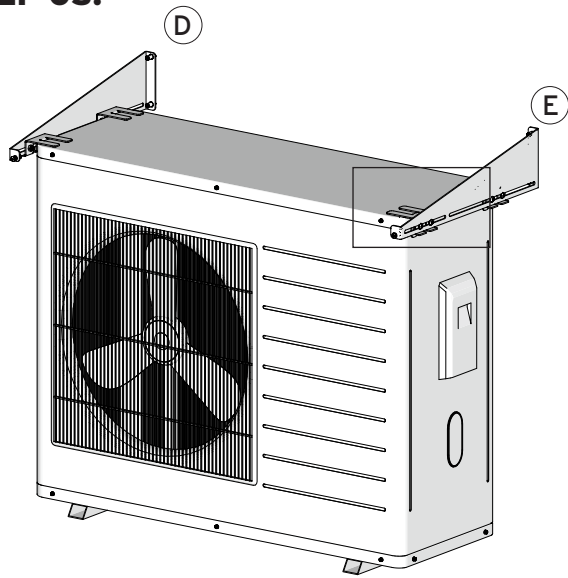

FASTEN SIDE PANELS (D & E) TO BRACKETS (C) WITH PARTS (G, H, & I) X8

STEP 04:

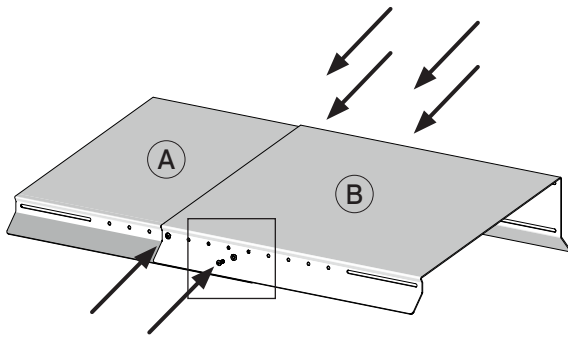

SLIDE PARTS (A & B) TOGETHER TO FORM COVER.

ADJUST COVER WIDTH TO ROUGHLY 4" WIDER THAN MINI SPLIT WIDTH.

FASTEN COVER TOGETHER WITH PARTS (G, H, & I).

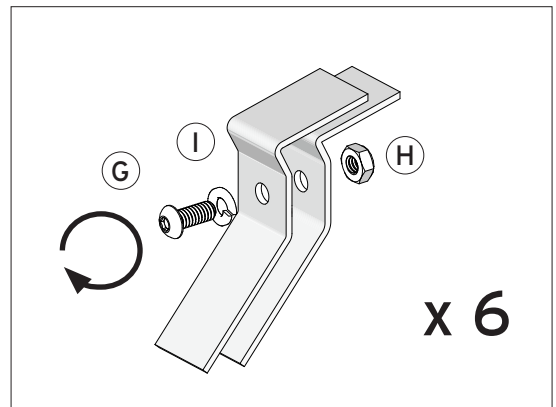

STEP 05:

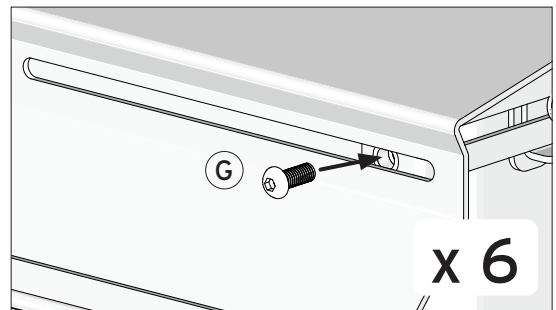
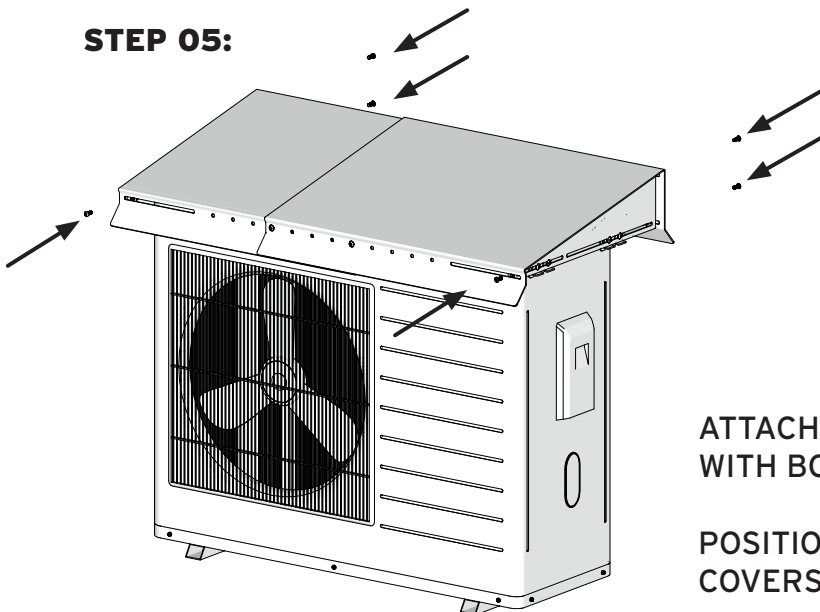

ATTACH ASSEMBLED COVER ONTO SIDE PANELS (D & E) WITH BOLT (G) X 6. DON'T FASTEN TOO TIGHTLY.

POSITION SNOW CAP TO THE LEFT AND BACK SO IT COVERS THE RADIATORS.

FASTEN BOLTS (G) TIGHTLY.

HANGAR

OUTDOOR

contact@hangaroutdoor.com