

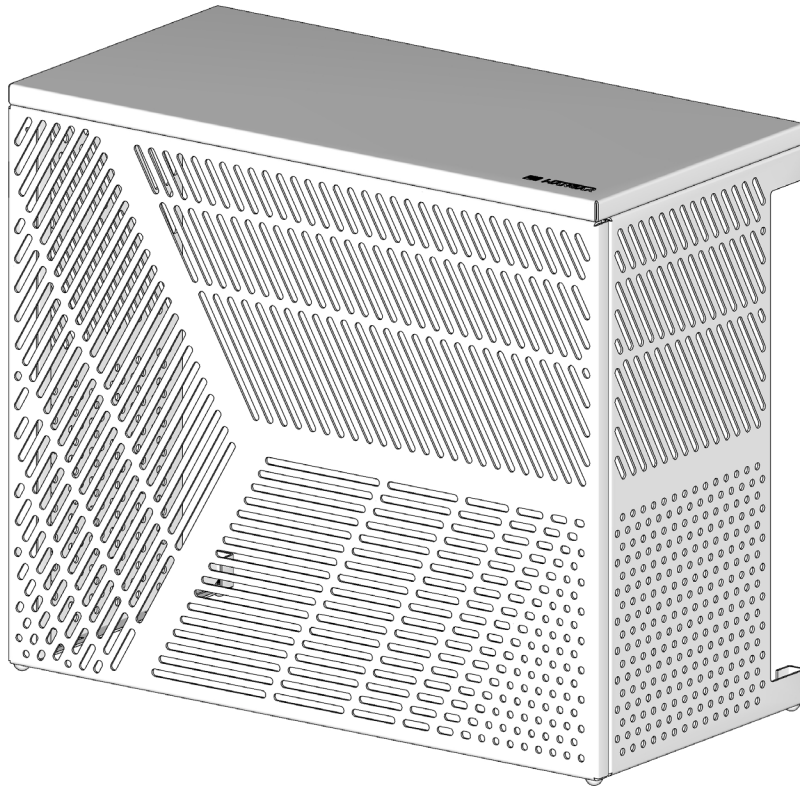

HANGAR

AIR CONDITIONING SHROUD



ASSEMBLY INSTRUCTIONS

INSTRUCTIONS:

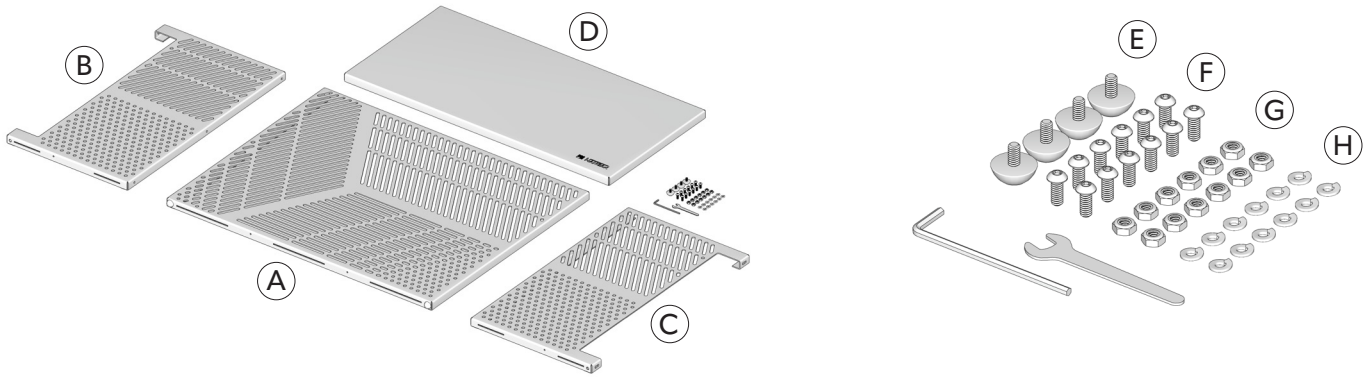

STEP 01:

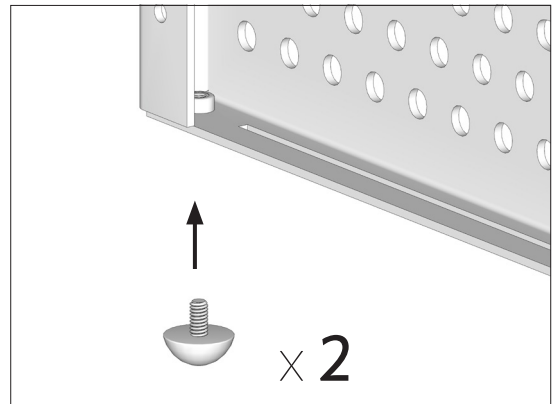
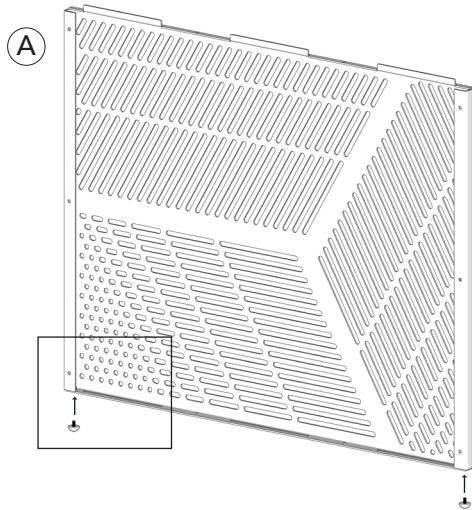

SCREW FOOTER HARDWARE (E)
INTO THREADS ON PART (A).

STEP 02:

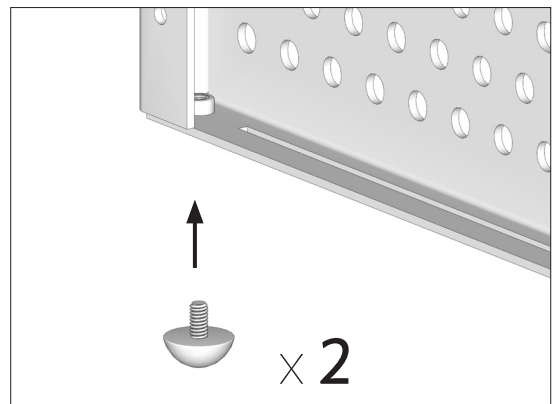
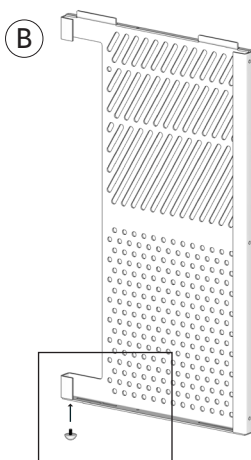

SCREW FOOTER HARDWARE (E)
INTO THREADS ON PART (B).
REPEAT STEP FOR PART (C).

STEP 03:

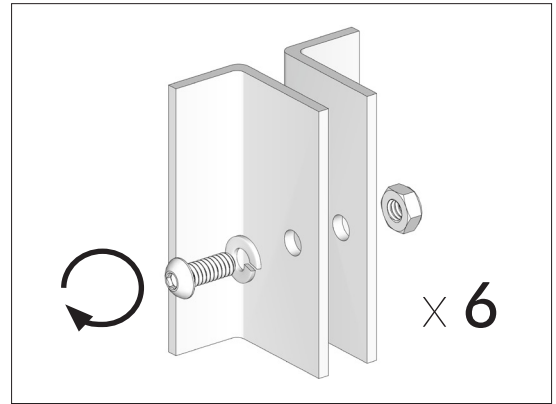
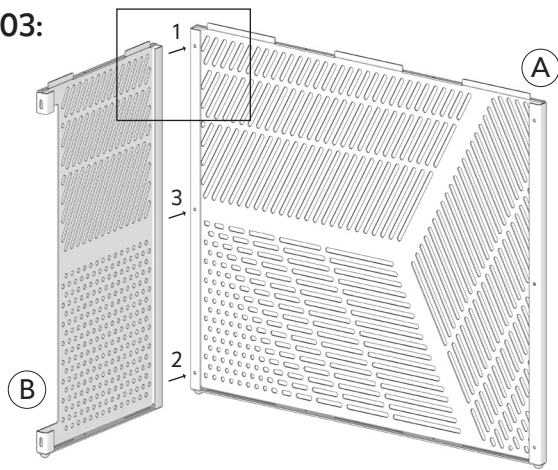

FASTEN HARDWARE (F-H) TO CONNECT PARTS (A & B). KEEP TABS FACING UPWARD. REPEAT FOR PART (C). LOOSELY THREAD ALL HARDWARE BEFORE TIGHTENING.

STEP 04:

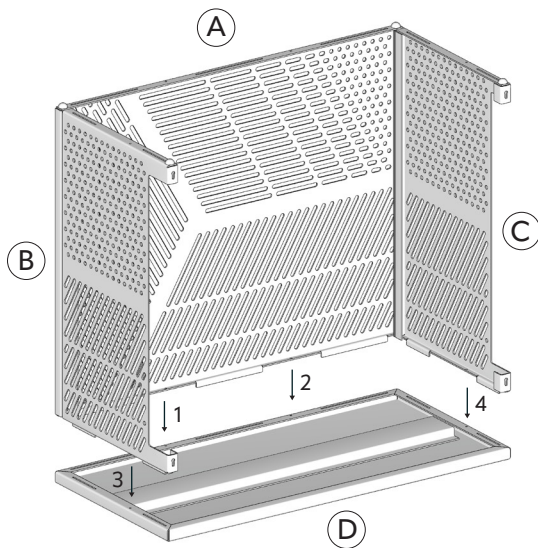

LAY LID (D) ON SOFT SURFACE UPSIDE DOWN.

INSERT SIDES (A,B,C) INTO LID SLOTS.

FASTEN HARDWARE (F-H) TO LOCK PANEL (D) INTO PLACE.

TIGHTEN ALL HARDWARE FIRMLY TO PREVENT MOVEMENT.

STEP 05:

MOVE HANGAR MINI SPLIT SHROUD INTO PLACE OVER AIR CONDITIONER.

KEEP VENTS FREE OF SEASONAL DEBRIS TO MAXIMIZE AIR FLOW.

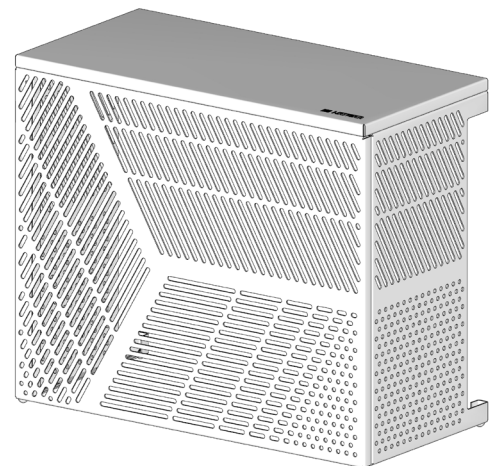



ELEVATE YOUR UTILITY
contact@hangaroutdoor.com